



2024

NOVEDADES
NEW PRODUCTS
NOUVEAUTÉS



izartool.com



Ref. **1032**

BROCA MANGO CILINDRICO METALMAX. SERIE CORTA

METALMAX Cobalt Drill Bit. Jobber Series

Foret cobalt METALMAX. Série courte



HSSE 5%Co	DIN 338 W						Ambar Gold Finish Finition Or	Rectificado Ground Taillé meulé	Tol. D h8
------------------	-----------	--	--	--	--	--	--	--	--------------

INOX Stainless Steel Acier INOX	Cobre Copper Cuivre	Aluminio Aluminium	Tubo Tube Tube	Chapa Sheet Tôle
--	----------------------------------	------------------------------	-----------------------------	-------------------------------



D mm	L mm	I mm		N° Art.	€
1,00	34	12	10	44820	
1,50	40	18	10	44822	
2,00	49	24	10	15169	
2,50	57	30	10	44823	
3,00	61	33	10	15191	
3,30	65	36	10	84181	
3,50	70	39	10	15193	
4,00	75	43	10	15215	
4,20	75	43	10	15238	
4,50	80	47	10	15243	
5,00	86	52	10	15244	
5,50	93	57	10	15247	
6,00	93	57	10	15265	
6,50	101	63	10	15270	
6,80	109	69	10	84182	

D mm	L mm	I mm		N° Art.	€
7,00	109	69	10	15273	
7,50	109	69	10	15280	
8,00	117	75	10	15282	
8,50	117	75	5	15283	
9,00	125	81	5	15285	
9,50	125	81	5	44825	
10,00	133	87	5	15291	
10,20	133	87	5	84183	
10,50	133	87	5	15292	
11,00	142	94	5	15298	
11,50	142	94	5	44828	
12,00	151	101	5	15303	
12,50	151	101	5	44831	
13,00	151	101	5	15304	

Expo - Ref. 1032

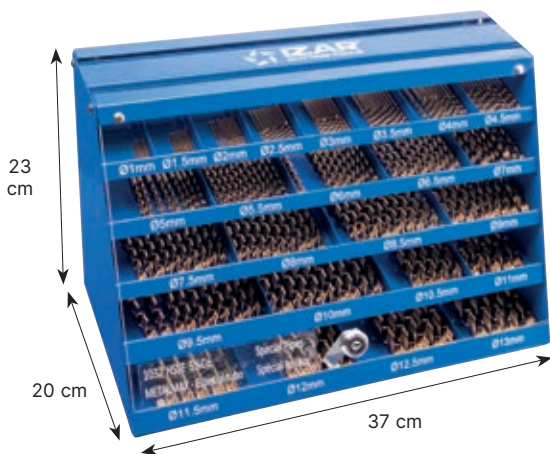

220 Pcs

∅	1	1,5	2	2,5	3	3,5	4	4,5
Pcs	10	10	10	10	10	10	10	10
∅	5	5,5	6	6,5	7			
Pcs	10	10	10	10	10			
∅	7,5	8	8,5	9				
Pcs	10	10	10	10				
∅	9,5	10	10,5	11				
Pcs	10	10	5	5				
∅	11,5	12	12,5	13				
Pcs	5	5	5	5				

N° Art. 41034: €



Ref. **1022**

BROCA COBALTO METALMAX

METALMAX Cobalt Drill Bit
Foret cobalt METALMAX



HSSE 5%Co	DIN 338 W						Ambar Gold Finish Finition Or	Rectificado Ground Taillé meulé	Tol. D h8
INOX Stainless Steel Acier INOX	Cobre Copper Cuivre	Aluminio Aluminium	Tubo Tube Tube	Chapa Sheet Tôle					

D mm	L mm	I mm		N° Art.	€	D mm	L mm	I mm		N° Art.	€
1,00	34	12	2	44618	*	6,80	109	69	1	84169	
1,50	40	18	2	44627	*	7,00	109	69	1	80127	
2,00	49	24	2	80135	*	7,50	109	69	1	81854	
2,50	57	30	2	44633	*	8,00	117	75	1	80116	
3,00	61	33	2	80125	*	8,50	117	75	1	81855	
3,30	65	36	2	84168	*	9,00	125	81	1	80131	
3,50	70	39	2	81844	*	9,50	125	81	1	44636	
4,00	75	43	2	80113	*	10,00	133	87	1	80117	
4,20	75	43	1	81845		10,20	133	87	1	84170	
4,50	80	47	1	81846		10,50	133	87	1	81856	
5,00	86	52	1	80114		11,00	142	94	1	81857	
5,50	93	57	1	81847		11,50	142	94	1	44642	
6,00	93	57	1	80115		12,00	151	101	1	81858	
6,50	101	63	1	81848		12,50	151	101	1	44645	
						13,00	151	101	1	81859	

* € = 2uds

Display 73 - Ref. 1022



∅	8	8,5	9	10	10,5	11	12	13
Pcs	5	5	3	3	2	2	2	2

∅	5	5	5,5	6	6	6,5	7	7,5
Pcs	3	2	5	3	2	5	5	5

∅	1,5	2	2,5	3	3,5	4	4	4,5
Pcs	3	3	3	5	5	3	2	5

Ref. 4995 - N° Art. 13781: €





Set **1462**

6 Pcs

Cont. Ø	Nº Art.	€
2 - 3 - 4 - 5 - 6 - 8 mm	80138	



Set **1459**

29 Pcs

Cont. Ø	Nº Art.	€
1 - 13 x 0,5 mm *	84159	

* + Previos Roscado / Before Threading
Pré-Tarudage (3,3 - 4,2 - 6,8 - 10,2 mm)



Set **1466**

19 Pcs

Cont. Ø	Nº Art.	€
1 - 10 x 0,5 mm	80139	



Set **1456**

25 Pcs

Cont. Ø	Nº Art.	€
1 - 13 x 0,5 mm	34348	

Sets **1404**

JUEGO BROCAS 99 PCS (1-10x0,1mm + 10-13x0,5mm + Previos roscado 10-13mm)
Drill Bit Set. **99 pcs.** (1-10x0,1mm + 10-13x0,5mm + Before Threading sizes 10-13mm)
Jeu de forets. **99 pcs.** (1-10x0,1mm + 10-13x0,5mm + Pré Tarudage 10-13mm)



Ref.
1016

Nº Art.	€
48821	

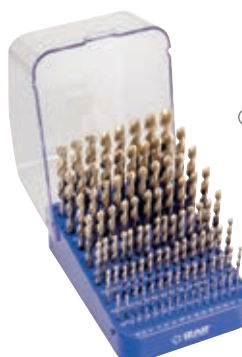

Ref.
1015

Nº Art.	€
48824	



Ref.
1013

Nº Art.	€
48818	

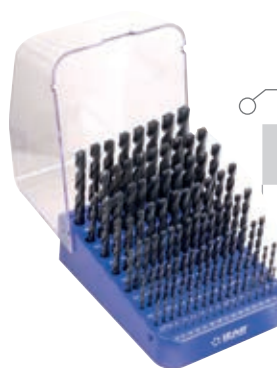

Ref.
1010

Nº Art.	€
48815	





Ref. **1052**

BROCA MANGO CILÍNDRICO HSS ZIRKONIO. SERIE EXTRA CORTA

HSS Zirkonio Straight Shank Drill Bit. Stub Series

Foret queue cylindrique HSS Zirkonio. Série extra-courte



ZIRKONIO



HSS	Zirkonio	DIN 1897 N	135°	DIN 1412 C ≥ 2 mm				Rectificado Ground Taillé meulé	Tol. D h8
-----	----------	------------	------	-------------------	--	--	--	---------------------------------------	-----------

Aceros <850 N/mm ² Steel / Aciers	Fundición Cast Iron Fonte	Aluminio Aluminium
---	--	------------------------------



D mm	L mm	I mm		N° Art.	€	D mm	L mm	I mm		N° Art.	€	D mm	L mm	I mm		N° Art.	€
1,00	26	6	10	44999		5,00	62	26	10	25064		9,10	84	40	10	45386	
1,10	28	7	10	48470		5,10	62	26	10	45212		9,20	84	40	10	48563	
1,20	30	8	10	48476		5,20	62	26	10	25066		9,25	84	40	10	45545	
1,25	30	8	10	45458		5,25	62	26	10	45512		9,30	84	40	10	48566	
1,30	30	8	10	48479		5,30	62	26	10	45218		9,40	84	40	10	48569	
1,40	32	9	10	48482		5,40	66	28	10	45221		9,50	84	40	10	25132	
1,50	32	9	10	45002		5,50	66	28	10	25072		9,60	89	43	10	48572	
1,60	34	10	10	45005		5,60	66	28	10	45224		9,70	89	43	10	48575	
1,70	34	10	10	48488		5,70	66	28	10	45227		9,75	89	43	10	45548	
1,75	36	11	10	45464		5,75	66	28	10	45515		9,80	89	43	10	48578	
1,80	36	11	10	45026		5,80	66	28	10	45230		9,90	89	43	10	48581	
1,90	36	11	10	45028		5,90	66	28	10	45341		10,00	89	43	10	25135	
2,00	38	12	10	24853		6,00	66	28	10	25075		10,10	89	43	1	48584	
2,10	40	13	10	45065		6,10	70	31	10	45353		10,20	89	43	1	25137	
2,20	40	13	10	45068		6,20	70	31	10	45356		10,25	89	43	1	45551	
2,25	40	13	10	48785		6,25	70	31	10	45524		10,30	89	43	1	48587	
2,30	40	13	10	45071		6,30	70	31	10	45359		10,50	89	43	1	25138	
2,40	43	14	10	45074		6,40	70	31	10	45362		10,80	95	47	1	48590	
2,50	43	14	10	24898		6,50	70	31	10	25078		11,00	95	47	1	25139	
2,60	43	14	10	24899		6,60	70	31	10	45365		11,10	95	47	1	48788	
2,70	46	16	10	45078		6,70	70	31	10	45368		11,20	95	47	1	48593	
2,75	46	16	10	45470		6,75	74	34	10	45527		11,25	95	47	1	45557	
2,80	46	16	10	45080		6,80	74	34	10	25081		11,50	95	47	1	45389	
2,90	46	16	10	45083		6,90	74	34	10	48494		11,80	95	47	1	48602	
3,00	46	16	10	24900		7,00	74	34	10	25085		12,00	102	51	1	25141	
3,10	49	18	10	45128		7,10	74	34	10	48497		12,10	102	51	1	48605	
3,20	49	18	10	24901		7,20	74	34	10	45374		12,20	102	51	1	48608	
3,25	49	18	10	24902		7,25	74	34	10	45530		12,25	102	51	1	45560	
3,30	49	18	10	24903		7,30	74	34	10	48503		12,50	102	51	1	25142	
3,40	52	20	10	45134		7,40	74	34	10	45377		12,70	102	51	1	45563	
3,50	52	20	10	24905		7,50	74	34	10	25091		13,00	102	51	1	25143	
3,60	52	20	10	45153		7,60	79	37	10	48506		13,50	107	54	1	45392	
3,70	52	20	10	45154		7,70	79	37	10	48533		14,00	107	54	1	45398	
3,75	52	20	10	45473		7,75	79	37	10	45536		14,50	111	56	1	45419	
3,80	55	22	10	45163		7,80	79	37	10	45380		15,00	111	56	1	45422	
3,90	55	22	10	45165		7,90	79	37	10	48539		15,25	115	58	1	48800	
4,00	55	22	10	24906		8,00	79	37	10	25102		15,50	115	58	1	45425	
4,10	55	22	10	24913		8,10	79	37	10	48542		15,75	115	58	1	48791	
4,20	55	22	10	24943		8,20	79	37	10	48548		16,00	115	58	1	45428	
4,25	55	22	10	45491		8,25	79	37	10	45539		16,50	119	60	1	45572	
4,30	58	24	10	25027		8,30	79	37	10	48551		17,00	119	60	1	45575	
4,40	58	24	10	45197		8,40	79	37	10	48554		17,50	123	62	1	45577	
4,50	58	24	10	25028		8,50	79	37	10	25106		18,00	123	62	1	45578	
4,60	58	24	10	45200		8,70	84	40	10	45383		18,50	127	64	1	45585	
4,70	58	24	10	45203		8,75	84	40	10	45542		19,00	127	64	1	45588	
4,75	58	24	10	45500		8,80	84	40	10	48557		19,50	131	66	1	45597	
4,80	62	26	10	45206		8,90	84	40	10	48560		20,00	131	66	1	45614	
4,90	62	26	10	25061		9,00	84	40	10	25130							



Sets **1410**

MEDIDOR DE DIÁMETROS

Diameter gauge
Jauge de diamètres



55 Pcs:

1-13 x 0,5 mm

- Ø1,0 – 4,0 mm: 3 pcs
- Ø4,2 – 8,0 mm: 2 pcs
- Ø8,50 – 13,0 mm: 1 pcs



Ref.
1016



Ref.
1015

Cont. Ø	Nº Art.	€
1 - 13 x 0,5 mm	19537	

Cont. Ø	Nº Art.	€
1 - 13 x 0,5 mm	28360	



Ref.
1010



Ref.
1013

Cont. Ø	Nº Art.	€
1 - 13 x 0,5 mm	19535	

Cont. Ø	Nº Art.	€
1 - 13 x 0,5 mm	19536	

Ref. **4073**

CONO PORTA FRESAS HUECAS

Holder for annular cutters

Cône pour porte-fraise à carotter pour unité de perçage électromagnétique

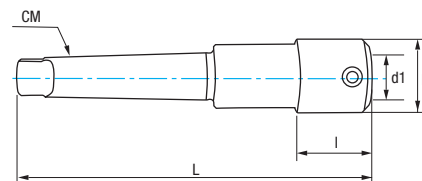

CM	D mm	L mm	I mm	d1 mm	Nº Art.	€
2	37	165	37	19	84115	
3	37	175	37	19	84116	



Llave Allen incluida - Allen key included - Clé Allen incluse



Ref. 3039

MACHO ÚNICO MANO MÉTRICA / MÉTRICA FINA NORMA ISO

ISO Standard Metric / Metric Fine Hand Single Tap

Taroud à main **único** métrica / métrica pas fin **norma ISO**

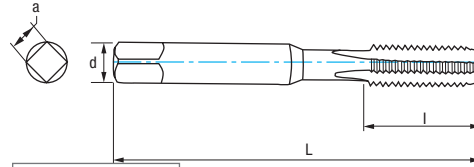

HSS	ISO 529	Tol. 6H		α 10° ± 2		Nº3 Acabado Finishing Finition
-----	---------	---------	--	------------------	--	--------------------------------

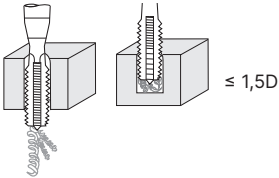

Grupo Group-Groupe	Subgrup. P.1	Grupo Group-Groupe	Grupo Group-Groupe	Subgrup. N.1 - N.3 N.4 - N.5
P		K	N	



M	P	L mm	l mm	d mm	a mm	Z	Nº Art.	€	Nº Art.	€	Nº Art.	€
M1	0,25	38,50	5,50	2,50	2,00	3	29121		29122		29123	
M1,2	0,25	38,50	5,50	2,50	2,00	3	29124		29125		29126	
M1,4	0,30	40,00	7,00	2,50	2,00	3	29127		29128		29129	
M1,6	0,35	41,00	8,00	2,50	2,00	3	29130		29131		29132	
M1,7	0,35	41,00	8,00	2,50	2,00	3	29133		29134		29159	
M1,8	0,35	41,00	8,00	2,50	2,00	3	29160		29162		29164	
M2	0,40	41,00	8,00	2,50	2,00	3	29171		29172		29175	
M2	0,45	41,00	8,00	2,50	2,00	3	29176		29177		29193	
M2,2	0,45	44,50	9,50	2,80	2,24	3	29195		29196		29197	
M2,3	0,45	44,50	9,50	2,80	2,24	3	29199		29211		29212	
M2,5	0,45	44,50	9,50	2,80	2,24	3	29214		29216		29217	
M2,6	0,45	44,50	9,50	2,80	2,24	3	29218		29234		29277	
MF3	0,35	48,00	11,00	3,15	2,50	3	45629		45644		45647	
M3	0,50	48,00	11,00	3,15	2,50	3	29475		29477		29484	
M3	0,60	48,00	11,00	3,15	2,50	3	29494		29633		29846	
MF3,5	0,35	48,00	11,00	3,15	2,50	3					45650	
M3,5	0,60	50,00	13,00	3,55	2,80	3	29861		29862		29865	
MF4	0,50	53,00	13,00	4,00	3,15	3	45659		45662		45665	
M4	0,70	53,00	13,00	4,00	3,15	3	29866		29867		29872	
M4	0,75	53,00	13,00	4,00	3,15	3	29879		29886		29887	
M4,5	0,75	53,00	13,00	4,00	3,15	3	29889		29890		29892	
MF5	0,50	58,00	16,00	5,00	4,00	3	45668		45671		45698	
MF5	0,75	58,00	16,00	5,00	4,00	3	45701		45705		45744	
M5	0,80	58,00	16,00	5,00	4,00	3	29943		29948		29956	
M5	0,90	58,00	16,00	5,00	4,00	3	29957		29966		29973	
M5,5	0,90	62,00	12,00	5,60	4,50	3	29982		29983		29984	
MF6	0,50	66,00	19,00	6,30	5,00	3	45819		45822		45845	
MF6	0,75	66,00	19,00	6,30	5,00	3	45854		45856		45859	
M6	1,00	66,00	19,00	6,30	5,00	3	29986		29987		30006	
MF7	0,75	66,00	19,00	7,10	5,60	3	45869		45875		45878	
M7	1,00	66,00	19,00	7,10	5,60	3	30007		30009		30010	
MF8	0,50	66,00	19,00	8,00	6,30	3	45884		45890		45893	
MF8	0,75	66,00	19,00	8,00	6,30	3	45902		45904		45917	
MF8	1,00	66,00	19,00	8,00	6,30	3	45931		45934		45935	
M8	1,25	66,00	19,00	8,00	6,30	3	30011		30013		30016	
MF9	0,75	66,00	19,00	9,00	7,10	3					45936	
MF9	1,00	72,00	22,00	9,00	7,10	3	45938		45939		45940	
M9	1,25	72,00	22,00	9,00	7,10	3	30017		30018		30020	
MF10	0,50	73,00	20,00	10,00	8,00	3					45942	
MF10	0,75	73,00	20,00	10,00	8,00	3	46031		46034		46037	
MF10	1,00	80,00	24,00	10,00	8,00	3	46040		46043		46046	
MF10	1,25	80,00	24,00	10,00	8,00	3	46049		46052		46055	
M10	1,50	80,00	24,00	10,00	8,00	3	30021		30063		30064	
MF11	0,75	80,00	22,00	8,00	6,30	4	46058		46061		46067	
MF11	1,00	80,00	22,00	8,00	6,30	4	46070		46075		46078	
MF11	1,25	80,00	22,00	8,00	6,30	4					46089	





M	P	L mm	I mm	d mm	a mm	Z	Nº Art.	€	Nº Art.	€	Nº Art.	€
M11	1,50	80,00	22,00	8,00	6,30	4	30065		30066		30067	
MF12	0,75	80,00	22,00	9,00	7,10	4					46091	
MF12	1,00	80,00	22,00	9,00	7,10	4	46093		46095		46098	
MF12	1,25	89,00	29,00	9,00	7,10	4	46101		46103		46104	
MF12	1,50	89,00	29,00	9,00	7,10	4	46105		46155		46156	
M12	1,75	89,00	29,00	9,00	7,10	4	30068		30069		30070	
MF13	1,50	89,00	29,00	9,00	7,10	4					46158	
MF14	1,00	87,00	22,00	11,20	9,00	4	46159		46161		46162	
MF14	1,25	95,00	30,00	11,20	9,00	4	46164		46165		46167	
MF14	1,50	95,00	30,00	11,20	9,00	4	46168		46169		46170	
M14	2,00	95,00	30,00	11,20	9,00	4	30071		30072		30073	
MF15	1,50	95,00	30,00	11,20	9,00	4			46171		46173	
MF16	1,00	92,00	22,00	12,50	10,00	4	46176		46177		46178	
MF16	1,25	102,00	32,00	12,50	10,00	4					46179	
MF16	1,50	102,00	32,00	12,50	10,00	4	46180		46181		46182	
M16	2,00	102,00	32,00	12,50	10,00	4	30074		30075		30076	
MF18	1,00	97,00	22,00	14,00	11,20	4	46183		46184		46315	
MF18	1,50	112,00	37,00	14,00	11,20	4	46327		46348		46525	
MF18	2,00	112,00	37,00	14,00	11,20	4	46531		46540		46631	
M18	2,50	112,00	37,00	14,00	11,20	4	30077		30078		30080	
MF20	1,00	102,00	22,00	14,00	11,20	4	46901		46823		46898	
MF20	1,50	112,00	37,00	14,00	11,20	4	46919		46925		46931	
MF20	2,00	112,00	37,00	14,00	11,20	4	46940		46967		46976	
M20	2,50	112,00	37,00	14,00	11,20	4	30082		30083		30085	
MF22	1,00	118,00	38,00	16,00	12,50	4			46979		46982	
MF22	1,50	118,00	38,00	16,00	12,50	4	46985		46988		46994	
MF22	2,00	118,00	38,00	16,00	12,50	4	46997		47000		47006	
M22	2,50	118,00	38,00	16,00	12,50	4	30086		30087		30088	
MF24	1,00	130,00	45,00	18,00	14,00	4			47012		47015	
MF24	1,50	130,00	45,00	18,00	14,00	4	47018		47021		47024	
MF24	2,00	130,00	45,00	18,00	14,00	4	47027		47033		47036	
M24	3,00	130,00	45,00	18,00	14,00	4	30089		30090		30091	
MF25	1,50	130,00	45,00	18,00	14,00	4	47198		47273		47276	
MF26	1,50	120,00	35,00	18,00	14,00	4			47279		47282	
MF27	1,50	127,00	37,00	20,00	16,00	4			47288		47300	
MF27	2,00	127,00	37,00	20,00	16,00	4					47435	
M27	3,00	127,00	37,00	20,00	16,00	4	30092		30093		30111	
MF28	1,50	127,00	37,00	20,00	16,00	4			47444		47453	
MF30	1,50	127,00	37,00	20,00	16,00	4			47960		47963	
MF30	2,00	127,00	37,00	20,00	16,00	4			47966		47969	
M30	3,50	127,00	37,00	20,00	16,00	4	30112		30113		30115	
MF32	1,50	137,00	37,00	22,40	18,00	4	48092		48095		48098	
MF33	2,00	137,00	37,00	22,40	18,00	4			48104		48107	
M33	3,50	137,00	37,00	22,40	18,00	4	30118		30120		30125	
MF35	1,50	144,00	39,00	25,00	20,00	4			48110		48113	
MF36	1,50	144,00	39,00	25,00	20,00	4					48140	
MF36	2,00	144,00	39,00	25,00	20,00	4			48149		48152	
MF36	3,00	144,00	39,00	25,00	20,00	4			48161		48164	
M36	4,00	144,00	39,00	25,00	20,00	4	30126		30138		30145	
MF39	3,00	170,00	60,00	28,00	22,40	4			48176		48188	
M39	4,00	170,00	60,00	28,00	22,40	4	30146		30147		30148	
MF40	1,50	149,00	39,00	28,00	22,40	4			48191		48194	
MF42	1,50	149,00	39,00	28,00	22,40	4			48197		48200	
MF42	3,00	149,00	39,00	28,00	22,40	4					48203	
M42	4,50	149,00	39,00	28,00	22,40	4	30149		30150		30151	
MF45	1,50	165,00	45,00	31,50	25,00	4			48206		48209	
M45	4,50	165,00	45,00	31,50	25,00	4	30152		30430		30459	
MF48	1,50	165,00	45,00	31,50	25,00	4					48212	
MF48	2,00	165,00	45,00	31,50	25,00	4					48218	
MF48	3,00	165,00	45,00	31,50	25,00	4					48224	
M48	5,00	187,00	67,00	31,50	25,00	4	30487		30493		30494	
MF50	1,50	165,00	45,00	31,50	25,00	4			48284		48287	
M52	5,00	200,00	70,00	35,50	28,00	4					30495	
M56	5,50	200,00	70,00	35,50	28,00	4					30500	



Ref. **3039**

MACHO ÚNICO MANO MÉTRICA / MÉTRICA FINA NORMA ISO

ISO Standard Metric / Metric Fine Hand Single Tap

Taraud à main unique métrique / métrique pas fin norme ISO

Ref. 3039 + 1015 Zirkonio



14 Pcs

Cont.	Nº Art. Zirkonio	€
Machos / Taps / Tarauds ISO 529: M3-M4-M5-M6-M8-M10-M12 Brocas / Drill Bits / Forets Zirkonio: 2,5-3,3-4,2-5,0-6,8-8,5-10,2	26020	



Ref. **3113**

MACHO HELICOIDAL MÁQUINA MÉTRICA NORMA ISO 529

ISO 529 Standard Metric Machine Spiral Tap

Taraud helicoidal machine métrique norme ISO 529

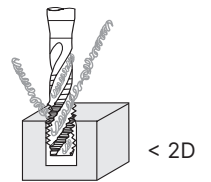
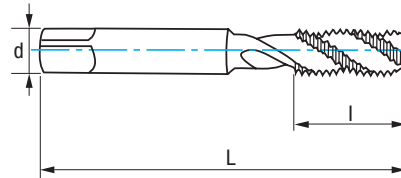

HSSE 5% Co	ISO 529	C 2-3h	Tol. 6H		α 12-14°		Vaporizado Vaporized Vaporisée
----------------------	-------------------	------------------	------------	--	--------------------	--	---

Aceros <850 N/mm ² Steel / Aciers	Cobre Copper Cuivre	Aluminio Aluminium
---	----------------------------------	------------------------------



M	P	L mm	l mm	d mm	a mm	Z	Nº Art.	€
M2	0,40	41	8	2,50	2,00	2	48989	
M2,5	0,45	44	9,5	2,80	2,24	2	48992	
M3	0,50	48	6	3,15	2,50	3	49004	
M3,5	0,60	50	6	3,55	2,80	3	49016	
M4	0,70	53	7	4,00	3,15	3	49019	
M5	0,80	58	8	5,00	4,00	3	49022	
M6	1,00	66	10	6,30	5,00	3	49025	
M7	1,00	66	13	7,10	5,60	3	49028	
M8	1,25	72	12	8,00	6,30	3	49031	
M10	1,50	80	15	10,00	8,00	3	49034	
M12	1,75	89	16	9,00	7,10	3	49187	
M14	2,00	95	18	11,20	9,00	3	49190	
M16	2,00	102	18	12,50	10,00	4	49193	
M18	2,50	112	29	14,00	11,20	4	49196	
M20	2,50	112	29	14,00	11,20	4	49199	
M22	2,50	118	29	16,00	12,50	4	49202	
M24	3,00	130	35	18,00	14,00	4	49205	
M27	3,00	135	35	20,00	16,00	4	77480	
M30	3,50	138	42	20,00	16,00	4	77481	



Ref. **3026**

JUEGO MACHOS MANO BSP (GAS)

BSP (Gas) Hand Tap Set
Jeu tarauds à main BSP (Gaz)

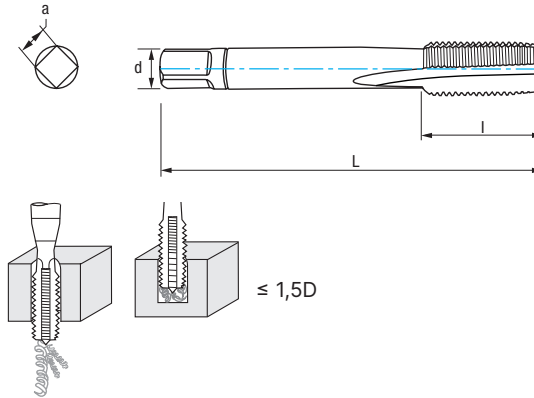

HSS	DIN 5157	ISO 2284	B 3,5-5h	C 2-3h		α $10^\circ \pm 2$		Rosca Whitworth Paralela (BSPP) Whitworth Parallel Thread (BSPP) Filetage Whitworth Parallèle (BSPP)
------------	----------	----------	--------------------	------------------	--	------------------------------	--	---

Aceros <math><850 \text{ N/mm}^2</math> Steel / Aciers	Fundición Cast Iron Fonte	Cobre Copper Cuivre	Aluminio Aluminium
---	--	----------------------------------	------------------------------

ISO 2284	Nº3 Acabado Finishing Finition
----------	---

Nº3



B
3,5-5h

Nº3



C
2-3h

G	Hilos Threads Filets	L mm	l mm	d mm	a mm	Z	Nº Art.	€
G1/8	28	59	15	8,00	6,30	4	26780	
G1/4	19	67	19	10,00	8,00	4	26789	
G3/8	19	75	21	12,50	10,00	4	26814	
G1/2	14	87	26	16,00	12,50	4	26830	
G5/8	14	91	26	18,00	14,00	4	26845	
G3/4	14	96	28	20,00	16,00	4	26852	
G7/8	14	102	29	22,40	18,00	6	26857	
G1"	11	109	33	25,00	20,00	6	26860	
G1" 1/8	11	116	34	28,00	22,40	6	26891	
G1" 1/4	11	119	36	31,50	25,00	6	26950	
G1" 3/8	11	120	36	31,50	25,00	6	26954	
G1" 1/2	11	125	37	35,50	28,00	6	26973	
G1" 3/4	11	132	39	35,50	28,00	6	26988	
G2"	11	140	41	40,00	31,50	6	27002	



Ref. **3016**

MACHO ÚNICO MANO BSP (GAS)

BSP (Gas) Hand Tap
Taraud à main BSP (Gaz)

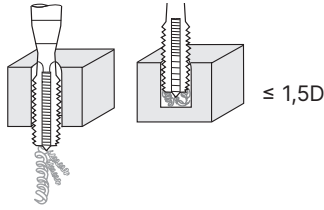
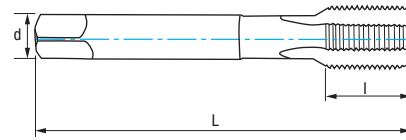

HSS	DIN 5157	ISO 2284		α $10^\circ \pm 2$	Rosca Whitworth Paralela (BSPP) Whitworth Parallel Thread (BSPP) Filetage Whitworth Parallèle (BSPP)	N°3 Acabado Finishing Finition
------------	----------	----------	--	------------------------------	---	---

Aceros <math><850 \text{ N/mm}^2</math> Steel / Aciers	Fundición Cast Iron Fonte	Cobre Copper Cuivre	Aluminio Aluminium
---	--	----------------------------------	------------------------------

ISO 2284	B 3,5-5h	C 2-3h
----------	--------------------	------------------

G	Entrada Chamfer Entrée	Hilos Threads Filets	L mm	I mm	d mm	a mm	Z	N° Art.	€
G1/8	B	28	59	15	8,00	6,30	4	26759	
	C							26779	
G1/4	B	19	67	19	10,00	8,00	4	26781	
	C							26783	
G3/8	B	19	75	21	12,50	10,00	4	26790	
	C							26791	
G1/2	B	14	87	26	16,00	12,50	4	26823	
	C							26827	
G5/8	B	14	91	26	18,00	14,00	4	26832	
	C							26843	
G3/4	B	14	96	28	20,00	16,00	4	26849	
	C							26850	
G7/8	B	11	102	29	22,40	18,00	6	26853	
	C							26855	
G1"	B	11	109	33	25,00	20,00	6	26858	
	C							26859	
G1" 1/8	B	11	116	34	28,00	22,40	6	26862	
	C							26873	
G1" 1/4	B	11	119	36	31,50	25,00	6	26941	
	C							26948	
G1" 3/8	B	11	120	36	31,50	25,00	6	26951	
	C							26953	
G1" 1/2	B	11	125	37	35,50	28,00	6	26956	
	C							26971	
G1" 3/4	B	11	132	39	35,50	28,00	6	26974	
	C							26976	
G2"	B	11	140	41	40,00	31,50	8	26991	
	C							26997	

N°3



Ref. **3103**

MACHO RECTO MÁQUINA UNC NORMA ISO 529

ISO 529 Norm Standard UNC Machine Straight Tap

Taraud droit machine UNC norme ISO 529

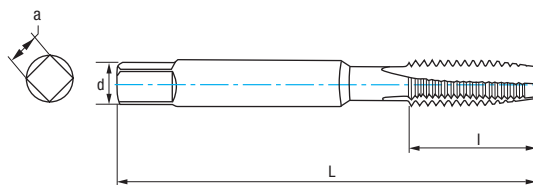

HSS	ISO 529	B 3,5-5h	C 2-3h	Tol. 6H	GUN	α 10-12°	60°
-----	---------	-------------	-----------	------------	-----	--------------------	-----

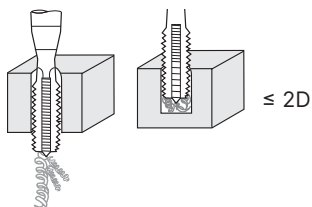

UNC	Hilos Threads Filets	L mm	l mm	d mm	a mm	Z	N° Art.	€	B 3,5-5h		C 2-3h	
									N° Art.	€	N° Art.	€
UNC N°1	64	41	8	2,50	2,00	3	62989		62990			
UNC N°2	56	45	10	2,80	2,24	3	62991		62992			
UNC N°3	48	45	10	2,80	2,24	3	62994		62995			
UNC N°4	40	48	11	3,15	2,50	3	62996		62997			
UNC N°5	40	48	11	3,15	2,50	3	62998		62999			
UNC N°6	32	50	13	3,55	2,80	3	63000		63001			
UNC N°8	32	53	13	4,50	3,55	3	63003		63004			
UNC N°10	24	58	16	5,00	4,00	3	63006		63007			
UNC N°12	24	62	17	5,60	4,50	3	63009		63012			
UNC 1/4	20	66	19	6,30	5,00	3	63016		63018			
UNC 5/16	18	72	22	8,00	6,30	3	63019		63021			
UNC 3/8	16	80	24	10,00	8,00	3	63022		63027			
UNC 7/16	14	85	25	8,00	6,30	3	63028		63030			
UNC 1/2	13	89	29	9,00	7,10	3	63031		63033			
UNC 9/16	12	95	30	11,20	9,00	3	63034		63036			
UNC 5/8	11	102	32	12,50	10,00	3	63038		63039			
UNC 3/4	10	112	37	14,00	11,20	3	63040		63042			
UNC 7/8	9	118	38	16,00	12,50	3	63043		63045			
UNC 1"	8	130	45	18,00	14,00	3	63046		63047			
UNC 1"1/8	7	138	48	20,00	16,00	4	63048		63049			
UNC 1"1/4	7	151	51	22,40	18,00	4	63051		63052			
UNC 1"3/8	6	162	57	25,00	20,00	4	63054		63057			
UNC 1"1/2	6	170	60	28,00	22,40	4	63058		63060			
UNC 1"3/4	5	187	67	31,50	25,00	4	63061		63063			
UNC 2"	4	200	70	35,50	28,00	4	63064		63066			



Ref. **3123**

MACHO RECTO MÁQUINA UNF NORMA ISO 529

ISO 529 Norm Standard UNF Machine Straight Tap

Taraud droit machine UNF norme ISO 529

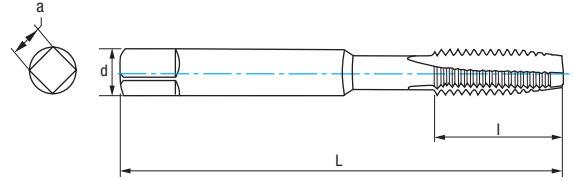

HSS	ISO 529	B 3,5-5h	C 2-3h	Tol. 6H	GUN	α 10-12°	60°
-----	---------	-------------	-----------	------------	-----	--------------------	-----

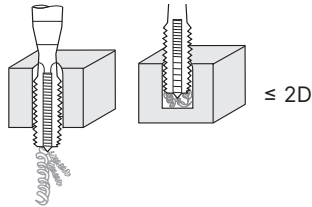

UNF	Hilos Threads Filets	L mm	l mm	d mm	a mm	Z	N° Art.	€	B 3,5-5h		C 2-3h	
									N° Art.	€	N° Art.	€
UNF N°0	80	41	8	2,50	2,00	3	63067			66203		
UNF N°1	72	41	8	2,50	2,00	3	63069			66205		
UNF N°2	64	45	10	2,80	2,24	3	63070			66398		
UNF N°3	56	45	10	2,80	2,24	3	84231			84232		
UNF N°4	48	48	11	3,15	2,50	3	63072			66410		
UNF N°5	44	48	11	3,15	2,50	3	63075			66413		
UNF N°6	40	50	13	3,55	2,80	3	63076			66509		
UNF N°8	36	53	13	4,50	3,55	3	63079			66512		
UNF N°10	32	58	16	5,00	4,00	3	63112			66566		
UNF N°12	28	62	17	5,60	4,50	3	63171			66596		
UNF 1/4	28	66	19	6,30	5,00	3	63172			66722		
UNF 5/16	24	72	22	8,00	6,30	3	63173			66728		
UNF 3/8	24	80	24	10,00	8,00	3	63174			67163		
UNF 7/16	20	85	25	8,00	6,30	3	63175			67169		
UNF 1/2	20	89	29	9,00	7,10	3	63177			67349		
UNF 9/16	18	95	30	11,20	9,00	3	63180			67358		
UNF 5/8	18	102	32	12,50	10,00	3	63181			67359		
UNF 3/4	16	112	37	14,00	11,20	3	63184			67361		
UNF 7/8	14	118	38	16,00	12,50	3	63213			67364		
UNF 1"	12	130	45	18,00	14,00	3	63326			67370		
UNF 1"1/8	12	127	37	20,00	16,00	4	63389			67373		
UNF 1"1/4	12	137	37	22,40	18,00	4	63392			67376		
UNF 1"3/8	12	144	39	25,00	20,00	4	63446			67394		
UNF 1"1/2	12	149	39	28,00	22,40	4	64121			67403		



Ref. **3560**

COJINETE MANO HEXAGONAL MÉTRICA / MÉTRICA FINA

Metric / Metric Fine HEX Hand Die

Filière à main hexagonale métrique / métrique pas fin

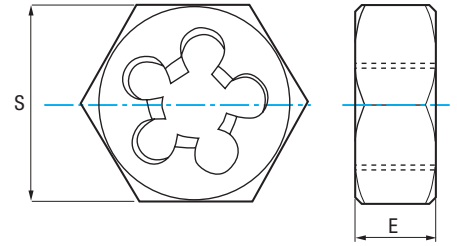

M/MF	P	S mm	E mm	N° Art.	€	M/MF	P	S mm	E mm	N° Art.	€	M/MF	P	S mm	E mm	N° Art.	€
MF3	0,35	19	5	84244		M11	1,50	27	11	84267		MF24	1,50	50	16	84288	
M3	0,50	19	5	84245		MF12	1,00	36	10	84268		MF24	2,00	50	16	84289	
M3,5	0,60	19	5	84246		MF12	1,25	36	10	84269		M24	3,00	50	22	84290	
MF4	0,50	19	5	84247		MF12	1,50	36	10	84270		MF26	1,50	60	18	84291	
M4	0,70	19	5	84248		M12	1,75	36	14	84271		MF27	1,50	60	18	84292	
M4,5	0,75	19	7	84249		MF14	1,00	36	10	84272		MF27	2,00	60	18	84293	
MF5	0,50	19	7	84250		MF14	1,25	36	10	84273		M27	3,00	60	25	84294	
M5	0,80	19	7	84251		MF14	1,50	36	10	84274		MF28	1,50	60	18	84295	
MF6	0,75	19	7	84252		M14	2,00	36	14	84275		MF30	1,50	60	18	84296	
M6	1,00	19	7	84253		MF16	1,50	41	14	84276		MF30	2,00	60	18	84297	
MF7	0,75	22	9	84254		M16	2,00	41	18	84277		M30	3,50	60	25	84298	
M7	1,00	22	9	84255		MF18	1,50	41	14	84278		MF32	1,50	60	18	84299	
MF8	0,75	22	9	84256		MF18	2,00	41	14	84279		MF33	1,50	60	18	84300	
MF8	1,00	22	9	84259		M18	2,50	41	18	84281		MF33	2,00	60	18	84301	
M8	1,25	22	9	84260		MF20	1,50	41	14	84283		M33	3,50	60	25	84302	
MF9	1,00	22	9	84261		MF20	2,00	41	14	84282		MF35	1,50	60	18	84303	
M9	1,25	22	9	84262		M20	2,50	41	18	84284		MF36	1,50	60	18	84304	
MF10	1,00	27	11	84263		MF22	1,50	50	16	84285		MF36	2,00	60	18	84305	
M10	1,50	27	11	84264		MF22	2,00	50	16	84286		MF36	3,00	60	18	84306	
MF11	1,00	27	11	84266		M22	2,50	50	16	84287		M36	4,00	60	25	84307	

- Para uso con llave fija, ajustable o de vaso
- Ideal para espacios limitados
- Recomendado para reparar roscas
- For use with a fixed, extendable, or socket wrench
- Ideal for tight spaces
- Recommended for rethreading threads
- Pour une utilisation avec une clé fixe, une clé extensible ou à douille
- Idéal pour les espaces restreints
- Recommandé pour réparer les filetages

Ref. **8352**

REBARBADOR EXTERIOR

External Chamfer Tool

Outil de chanfrein externe

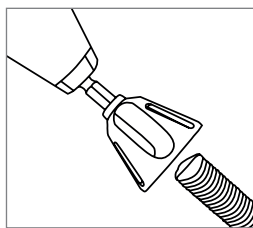

Cap.	N° Art.	€
Ø 6 - 25 mm	25381	





JUEGOS FRESAS ROTATIVAS MD CALIDAD PROFESIONAL

Professional Quality HM Rotary Burr Sets

Jeux fraises limes rotatives carbure qualité professionnelle



6 Sets

Nº Art.	€
58925	



Set 8 Pcs

Nº Art.	€
58922	

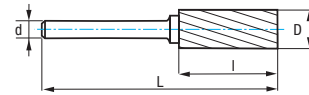

Cont.

Tipo Type	D mm	d mm	L mm	I mm
D	6	6	52	5
	10	6	53	9
C	6	6	61	16
	10	6	65	20
F	10	6	65	20
	12	6	70	25
B	10	6	65	20
	12	6	70	25

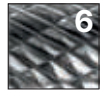

6 Sets

Nº Art.	€
58928	



Set 10 Pcs

Nº Art.	€
58920	

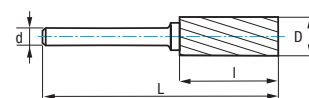

Cont.

Tipo Type	D mm	d mm	L mm	I mm
L	6	6	61	16
	10	6	70	25
F	6	6	63	18
	10	6	65	20
B	6	6	61	16
	10	6	65	20
C	6	6	61	16
	10	6	65	20
E	6	6	61	16
D	8	6	52	7



Ref. 9200

JUEGOS FRESAS ROTATIVAS MD

HM Rotary Burr Sets

Jeux fraises limes rotatives carbure



Mod. 5
5 Pcs



INOXIDABLES
Stainless Steels
Aciers Inox

Cont. (1 x ref.)	D mm	d mm	Dentado Teeth / Denture	
			Nº Art.	€
9251				
9254	12,70	6,00	84379	
9257				
9258	9,60	6,00	84380	
9268				



Una broca para TODOS los materiales

One Drill Bit for ALL Materials

Un foret pour TOUS les matériaux

Ref. **1876**

BROCA PUNTA METAL DURO MULTIPROPÓSITO

MultiPurpose Carbide Tipped Drill Bit
Foret pointe carbure Multifonction



MULTIMAT



Video



Hormigón
Concrete
Béton

Ladrillo
Brick
Brique

Cerámica
Ceramics
Céramique

Porcelánico Blando
Soft Porcelain
Porcelaine tendre

Aceros
Steels
Aciers

Madera
Wood
Bois

Plásticos
Plastics
Plastiques

D mm	L mm	I mm		Nº Art.	€
3	70	35	1	25533	
4	75	40	1	25534	
5	85	50	1	25536	
6	100	65	1	25539	
8	120	70	1	25542	
10	120	70	1	25546	
12	150	90	1	25549	

D mm	L mm	I mm		Nº Art.	€
6	150	90	1	25540	
8	150	90	1	25543	
10	150	90	1	25548	

- Punta de metal duro con afilado exclusivo IZAR
- Apta para trabajar con percusión (hormigón) y rotación (ladrillo, cerámica, chapa, madera y plásticos)
- Canales amplios, mejor desahogo del polvo / viruta
- Permite trabajo en seco, optimizado con refrigeración
- Perforación con precisión
- Geometría innovadora que permite una rápida perforación
- Tratamiento superficial IZAR BLUE, evita la adherencia del polvo / viruta

- Carbide Tip with exclusive Sharpening
- Suitable for working with Percussion (Concrete) & Rotation (Brick, Ceramics, Sheets, Wood & Plastic)
- Wide Flutes, better dust / chip relief
- Dry Running allowed, optimized with Cooling
- Drilling with Precision
- Innovative Geometry that allows Fast Drilling
- IZAR BLUE Surface Treatment, prevents the adhesion of dust / chips

- Pointe carbure avec affûtage exclusif
- Convient pour travailler avec percussion (béton) et rotation (brique, céramique, tôle, bois et plastique)
- Goujure large, meilleur soulagement des poussières / copeaux
- Travail à sec, optimisé avec réfrigération
- Perçage avec précision
- Géométrie innovante qui permet un perçage rapide
- Traitement de surface IZAR BLUE, empêche l'adhérence des poussières / copeaux



Una broca para TODOS los materiales
 One Drill Bit for ALL Materials
 Un foret pour TOUS les matériaux



Set **1876**

Set 6 Pcs

Cont. Ø	Nº Art.	€
3-4-5-6-8-10 mm	70478	



6 Sets

Nº Art.	€
53481	

Display 72 - Ref. 1876



Ø	3	4	5	5	6	6	8	8	10	12
Pcs	5	5	5	5	5	5	5	5	5	5

Ref. 4995 - Nº Art. 40228: €



Display 09 - Refs. 1880 - 1836 - 1876

BROCAS PARED, VIDRIO, MULTIPROPÓSITO
 Masonry, Glass, MultiPurpose Drill Bits
 Forets maçonnerie, verre, multifonction



Ref. 1880	Ø	3 L60	4 L75	5 L85	6 L100	7 L100	8 L120	9 L120	10 L120	12 L150	14 L150
	Pcs	5	5	10	10	5	6	3	3	3	3
Ref. 1836	Ø	3	4	4	5	5	6	6	8	8	10
	Pcs	5	3	2	3	2	3	2	3	2	5
Ref. 1876	Ø	3	4	5	5	6	6	8	8	10	12
	Pcs	5	5	5	5	5	5	5	5	5	5

Ref. 4995 - Nº Art. 22410: €



Ref. **1821**

BROCA PUNTA METAL DURO PARED PRO 4Z+ MANGO 3 PLANOS

3-Flat Shank 4Z+ Professional Concrete Carbide Tipped Drill Bit

Foret pointe carbure béton professionnel 4Z+ queue 3 plans



MD/HM
TCT



4 Z



Hormigón
Concrete
Béton

Hormigón Bloque
Concrete Block
Parpaing



D mm	L mm	I mm		Nº Art.	€
5	85	50	1	26220	
5,5	85	50	1	84585	
6	100	60	1	26221	
7	100	60	1	84586	
8	120	80	1	26285	
9	120	80	1	84587	
10	120	80	1	26287	
11	150	100	1	84588	
12	150	90	1	26360	
13	150	100	1	84589	
14	150	80	1	84590	
16	150	80	1	84591	

D mm	L mm	I mm		Nº Art.	€
5	150	100	1	84571	
6	150	100	1	84572	
8	200	150	1	84573	
10	200	150	1	84575	
12	200	150	1	84599	



Set 5 Pcs

D mm	Nº Art.	€
5, 6, 8, 10, 12	69406	



6 Sets

Nº Art.	€
69408	

Línea 33 cm - Ref. 1821

ø	5	6	8	10	12
	Pcs	10	10	10	10

Ref. 4995 - Nº Art. 84075: €

Display 80 - Refs. 1821 - 1846



BROCAS PARED PRO
Concrete Pro Drill Bits
Forets béton Pro

Ref.	ø	12 L200	8 L400	10 L400	12 L400	14 L400	16 L400	18 L400	20 L400
Ref. 1846	Pcs	1	3	3	3	3	3	2	2
Ref. 1821	ø	12	14	16	5 L150	6 L150	8 L200	10 L200	12 L200
Ref. 1821	Pcs	5	5	5	5	5	5	3	2
Ref. 1821	ø	5	5	6	7	8	8	9	10
Ref. 1821	Pcs	10	5	5	5	5	5	5	5

Ref. 4995 - Nº Art. 85813: €



Ref. **8318**

CUTER HOJA PARTIBLE 18 MM

18 mm Snap-Off Blade Box Cutter
Couteau à lames rétractables 18 mm

MOD. 18-ERG



Mod.	Hoja Blade / Lame mm		Nº Art.	€
18-ERG	18	1	83359	



- Cuchilla de 15 Segmentos
- 15 segment blade
- Lame à 15 segments



- Ergonómico. ABS para mejor agarre
- Ergonomic. ABS for better grip
- Ergonomique. ABS pour une melleure prise



- Portacuchillas inoxidable
- Stainless blade holder
- Porte-lames inoxydabile



Box-Pallet
8320

24 uds

Nº Art.	€
10177	

Ref. **8331**

CUCHILLAS REPUESTO - Spare Blades - Lames de rechange



Mod.	Hoja Blade / Lame mm		Nº Art.	€ 1 ud.
18-ERG	18	10	83765	



Box-Pallet
8320

20 uds

Nº Art.	€
12676	



Ref. **8319**

CUTER HOJA SEGURIDAD 19 MM

19 mm Security Blade Box Cutter
Couteau à lame sécurité 19 mm

New! MOD. 19S-RET



- Recogida semiautomática de la cuchilla después del corte, evitando lesiones.
- Mango ergonómico
- Cambio de cuchilla rápido y sencillo. Incluye 3 cuchillas
- After cutting, semi-automatic Blade collection, avoiding injuries.
- Ergonomic handle
- Quick Blade change. Includes 3 blades.
- Ramassage semi-automatique de la lame après la coupe, pour éviter des blessures
- Poignée ergonomique
- Changement de lame rapide et facile. Comprend 3 lames.

Mod.	Hoja Blade / Lame mm		Nº Art.	€
19S-RET	59x19x0,61	1	83360	



Box-Pallet
8320

6 uds

Nº
Art. €

10174

Ref. **8331**

CUCHILLAS REPUESTO

Spare Blades
Lames de rechange

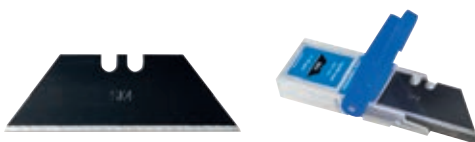

Mod.	Hoja Blade / Lame mm		Nº Art.	€ 1 ud.
New! 19S-RET-TRA	59x19x0,61	10	83766	

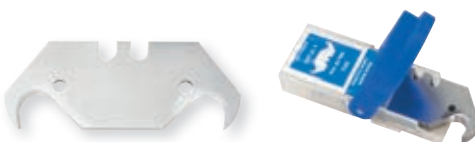

Mod.	Hoja Blade / Lame mm		Nº Art.	€ 1 ud.
New! 19S-RET-GAN	Gancho Hook / Crochet	10	83767	



Box-Pallet
8320

20 uds

Nº
Art. €

12677



Box-Pallet
8320

20 uds

Nº
Art. €

12682



Ref. **1692**

BROCA MADERA ESPIRAL SDS PLUS

SDS plus Wood Auger Bit
Foret bois spirale SDS plus

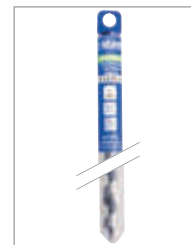

Maderas Duras
Hard Wood
Bois dur

D mm	L mm	I mm		Nº Art.	€
6	230	160	1	79143	
8	230	160	1	79183	
10	230	160	1	79210	
12	230	160	1	79224	
14	230	160	1	79243	
16	230	160	1	79245	
18	230	160	1	79247	
20	230	160	1	79259	

D mm	L mm	I mm		Nº Art.	€
6	460	370	1	79266	
8	460	370	1	79267	
10	460	370	1	79268	
12	460	370	1	79271	
14	460	370	1	79285	
16	460	370	1	79301	
18	460	370	1	79303	
20	460	370	1	79306	
24	460	370	1	84081	
26	460	370	1	84082	



Ref. **1616**

BROCA MANGO E6.3 COBALTO

Cobalt E6.3 Shank Drill Bit
Foret queue E6.3 Cobalt



HSSE 5% Co							Ambar Gold Finish Finition Or	Rectificado Ground Taillé meulé	Materiales Duros Hard Materials Matériaux durs
-------------------	--	--	--	--	--	--	---	---	---

Aceros <1300 N/mm² Steel / Aciers	INOX Ferríticos-Martensíticos Ferritic-Martensitic Stainless INOX Ferritiques-Martensitiques	Titanio Titanium Titane	1 sola pieza solid piece seule pièce
---	---	--------------------------------------	---

- Fabricada en una sola pieza:** soporta adecuadamente el par de torsión que liberan los atornilladores de impacto más potentes
- Fabricada con las mismas exigencias de calidad** que el resto de nuestras brocas
- Produced in 1 solid piece:** It can stand properly the large torque of the impact drivers
- Manufactured with the same high quality standards as in the rest of our drill bits
- Fabriquée en une seule pièce:** Il supporte adéquatement le couple de torsion libéré par les visseuses Impact les plus puissantes
- Fabriquée avec la même exigence que le reste de nos forets

D mm	L mm	I mm	d mm		Nº Art.	€
2,00	68	24	6,35	1	23094	
2,50	68	24	6,35	1	23097	
3,00	68	24	6,35	1	23099	
3,30	70	39	6,35	1	23103	
3,50	70	39	6,35	1	23107	
4,00	75	43	6,35	1	23111	
4,20	75	43	6,35	1	23114	
4,50	80	47	6,35	1	23120	
5,00	86	52	6,35	1	23123	
5,50	93	57	6,35	1	23125	
6,00	93	57	6,35	1	23129	
6,50	101	63	6,35	1	23131	

D mm	L mm	I mm	d mm		Nº Art.	€
7,00	109	69	6,35	1	23149	
7,50	109	69	6,35	1	23151	
8,00	117	75	6,35	1	23153	
8,50	117	75	6,35	1	23155	
9,00	125	81	6,35	1	23157	
9,50	125	81	6,35	1	23159	
10,00	133	87	6,35	1	23161	
10,50	133	87	6,35	1	23163	
11,00	142	94	6,35	1	23165	
11,50	142	94	6,35	1	23167	
12,00	151	101	6,35	1	23169	
12,50	151	101	6,35	1	23171	
13,00	151	101	6,35	1	23173	



Nº Art. €
86261



Set 5 Pcs

Cont. Ø	Nº Art.	€
3-4-5-6-8 mm	35267	

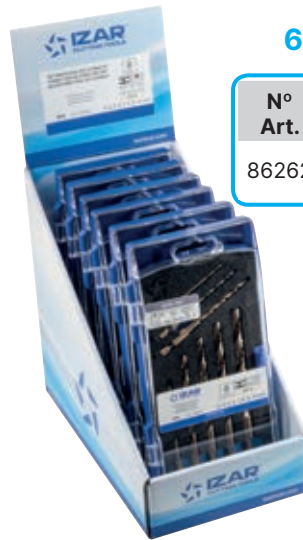

6 Sets

Nº Art. €
86262



Set 8 Pcs

Cont. Ø	Nº Art.	€
3-4-5-6-7-8-9-10 mm	35268	

Display 74



28 cm

Ø	2	3	4	4,5	5	6	7	8	9	10
Pcs	5	5	5	5	5	5	3	3	3	3

Ref. 4995 - Nº Art. 84044: €



Ref. **1613**

BROCA MANGO E6.3 HSS

HSS E6.3 Shank Drill Bit
Foret queue E6.3 HSS



HSS							Blanca Bright Finish Finition blanche	Rectificado Ground Taillé meulé	Usos General General Purpose Utilisation générale
-----	--	--	--	--	--	--	---	---------------------------------------	---

Aceros <850 N/mm ² Steel / Aciers	Fundición Cast Iron Fonte	Aluminio Aluminium
---	--	------------------------------

1 sola pieza
solid piece
seule pièce

- Fabricada en una sola pieza:** soporta adecuadamente el par de torsión que liberan los atornilladores de impacto más potentes
- Fabricada con las mismas exigencias de calidad** que el resto de nuestras brocas
- Produced in 1 solid piece:** It can stand properly the large torque of the impact drivers
- Manufactured with the same high quality standards as in the rest of our drill bits
- Fabriqué en une seule pièce:** Il supporte adéquatement le couple de torsion libéré par les visseuses Impact les plus puissantes
- Fabriqué avec la même exigence que le reste de nos forets

D mm	L mm	l mm	d mm		Nº Art.	€
2,00	68	24	6,35	1	23093	
2,50	68	24	6,35	1	23096	
3,00	68	24	6,35	1	23098	
3,30	70	39	6,35	1	23100	
3,50	70	39	6,35	1	23106	
4,00	75	43	6,35	1	23109	
4,20	75	43	6,35	1	23113	
4,50	80	47	6,35	1	23115	
5,00	86	52	6,35	1	23121	
5,50	93	57	6,35	1	23124	
6,00	93	57	6,35	1	23127	
6,50	101	63	6,35	1	23130	

D mm	L mm	l mm	d mm		Nº Art.	€
7,00	109	69	6,35	1	23148	
7,50	109	69	6,35	1	23150	
8,00	117	75	6,35	1	23152	
8,50	117	75	6,35	1	23154	
9,00	125	81	6,35	1	23156	
9,50	125	81	6,35	1	23158	
10,00	133	87	6,35	1	23160	
10,50	133	87	6,35	1	23162	
11,00	142	94	6,35	1	23164	
11,50	142	94	6,35	1	23166	
12,00	151	101	6,35	1	23168	
12,50	151	101	6,35	1	23170	
13,00	151	101	6,35	1	23172	



6 Sets

Nº Art.	€
86263	



Set 5 Pcs

Cont. Ø	Nº Art.	€
3-4-5-6-8 mm	35269	



6 Sets

Nº Art.	€
86264	



Set 8 Pcs

Cont. Ø	Nº Art.	€
3-4-5-6-7-8-9-10 mm	35270	

Display 75



Ø	2	3	4	4,5	5	6	7	8	9	10
Pcs	5	5	5	5	5	5	3	3	3	3

Ref. 4995 - Nº Art. 84048: €



Ref. 1622

BROCA ESCALONADA ESPIRAL MANGO E6.3

E6.3 Shank Spiral Step Drill Bit
Foret étagé spirale queue E6.3

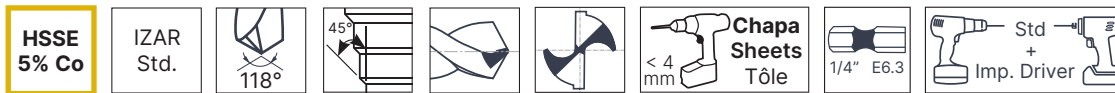
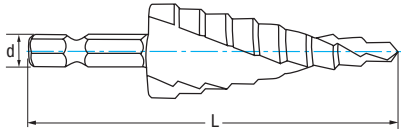

Aceros <850 N/mm ² Steel / Aciers	INOX Stainless Steel Acier INOX	Cobre Copper Cuivre	Aluminio Aluminium	Termoplásticos Thermoplastics Thermoplastiques
---	--	----------------------------------	------------------------------	---

- | | | |
|--|--|---|
| <ul style="list-style-type: none"> - Punta robusta autocentrante - Avellanado especial 45° - Menor desgaste y esfuerzo de corte - Mayor rendimiento y vida útil de la herramienta - Mejor evacuación de viruta - Acabado sin rebabas | <ul style="list-style-type: none"> - Autocentering robust point - Special 45° Countersinking - Lower wear and cutting effort - Better performance & longer tool life - Better chipping-off - No-burr finishing | <ul style="list-style-type: none"> - Pointe plus robuste autocentrante - Ébavurage special à 45° - Réduction de l'usure et de l'effort de coupe - Augmentation de la performance et vie utile de l'outil - Meilleure évacuation des copeaux - Finition sans bavures |
|--|--|---|

Cap. mm	Nº Pasos Steps / Étages	L mm	d mm	Nº Art.	€
4-12	9 (4-5-6-7-8-9-10-11-12)	70	6,35	59000	
4-20	9 (4-6-8-10-12-14-16-18-20)	77	6,35	59003	
6-30	13 (6-8-10-12-14-16-18-20-22-24-26-28-30)	98	6,35	59006	



3 Pcs

Cont.	Nº Art.	€
4-12, 4-20, 6-30 mm	86553	

Línea 33 cm - Ref. 1622

21 cm		∅	4-12	4-20	6-30
		Pcs	2	2	2
Ref. 4995 - Nº Art. 84051:					€

Display 79 - Refs. 1622 - 1635

22 cm		Ref. 1622				Ref. 1635				
		∅	4-12	4-20	6-30	6-30	12	12	16	19
		Pcs	3	3	3	3	3	3	3	3
Ref. 4995 - Nº Art. 85252: €										



Ref. **3610**

MACHO RECTO MÉTRICA MANGO E6.3

E6.3 Shank Metric Straight Tap
Taraud droit métrique queue E6.3

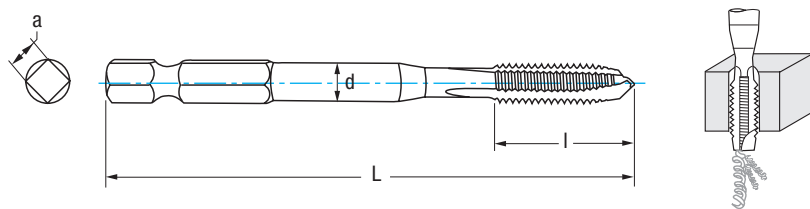

HSSE 5% Co	B 3,5-5h GUN	Tol. 6H	60°		 Chapa Sheets Tôle < 7 mm	 1/4" E6.3	 Std + Imp. Driver
----------------------	--------------------	------------	-----	--	---------------------------------------	---------------	--------------------------

Aceros <850 N/mm ² Steel / Aciers	Cobre Copper Cuivre	Aluminio Aluminium
---	----------------------------------	------------------------------

M	P	L mm	l mm	d mm	a mm		Nº Art.	€
M3	0,50	56	11	3,50	6,35	1	26706	
M4	0,70	63	13	4,50	6,35	1	26708	
M5	0,80	70	16	6,00	6,35	1	26717	
M6	1,00	80	19	6,00	6,35	1	26718	
M8	1,25	90	22	8,00	6,35	1	26719	
M10	1,50	100	24	10,00	6,35	1	26720	
M12	1,75	110	29	9,00	6,35	1	26721	

Línea 33 cm - Ref. 3610



∅	M3	M5	M6	M8	M10
Pcs	3	3	3	3	3

Ref. 4995 - Nº Art. 84054: €

Display 78 - Refs. 3610 - 3650



∅	Ref. 3610					Ref. 3650				
	M3	M5	M6	M8	M10	M3	M5	M6	M8	M10
Pcs	3	3	3	3	3	3	3	3	3	3

Ref. 4995 - Nº Art. 85251: €



Ref. **3650**

MACHO HELICOIDAL MÉTRICA MANGO E6.3

E6.3 Shank Metric Spiral Tap
Taraud Hélicoïdal métrique queue E6.3

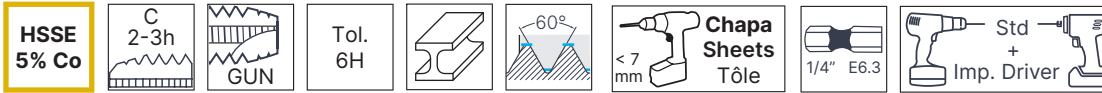
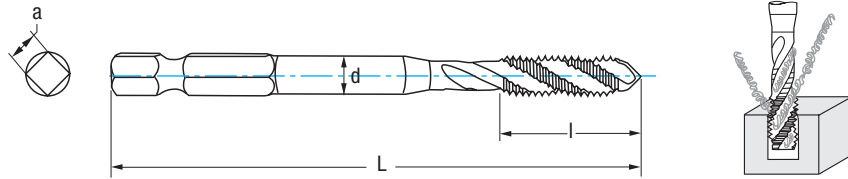

- Para roscado a mano no se recomiendan profundidades >7 mm, dado que la vibración podría causar roturas de los machos
- When threading by hand, not recommended for depths >7 mm, as the vibration could break the tap
- Pour le taraudage à main, il est déconseillé d'aller au-delà de 7 mm de profondeur, car les vibrations pourraient causer des ruptures des tarauds

M	P	L mm	l mm	d mm	a mm		Nº Art.	€
M3	0,50	56	11	3,50	6,35	1	26723	
M4	0,70	63	13	4,50	6,35	1	26725	
M5	0,80	70	16	6,00	6,35	1	26726	
M6	1,00	80	19	6,00	6,35	1	26727	
M8	1,25	90	22	8,00	6,35	1	26728	
M10	1,50	100	24	10,00	6,35	1	26730	
M12	1,75	110	29	9,00	6,35	1	26731	

Línea 33 cm - Ref. 3650



∅	M3	M5	M6	M8	M10
Pcs	3	3	3	3	3

Ref. 4995 - Nº Art. 84057: €



Ref. **1614**

BROCA-MACHO-AVELLANADOR MANGO E6.3

E6.3 Shank Combi Tap with Countersink
Outil multi-fonction queue E6.3

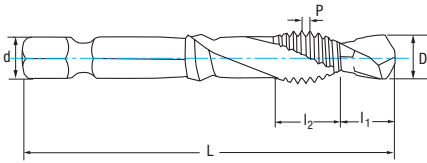

Aceros
<850 N/mm²
Steel / Aciers

Aluminio
Aluminium

D mm	P	L mm	l1 mm	l2 mm	d mm	Avellanado Countersinking Fraisage mm		Nº Art.	€
M3	0,50	52	8,10	8,90	6,35	7,20	1	53437	
M4	0,70	52	8,60	8,90	6,35	7,20	1	53449	
M5	0,80	56	8,90	11,90	6,35	7,20	1	53458	
M6	1,00	56	8,90	11,90	6,35	7,20	1	53463	
M8	1,25	57	8,90	11,90	6,35	9,10	1	53466	
M10	1,50	58	9,60	14,00	6,35	10,80	1	53469	
M12	1,75	69	12,70	14,00	6,35	12,80	1	53472	



6 Sets

Nº Art.	€
84155	



Set 7 Pcs

Cont.	Nº Art.	€
M3-M4- M5-M6- M8-M10- M12	84151	

Línea 33 cm - Ref. 1614

∅	3	4	5	6	8
	Pcs	3	3	3	3

Ref. 4995 - Nº Art. 84060: €

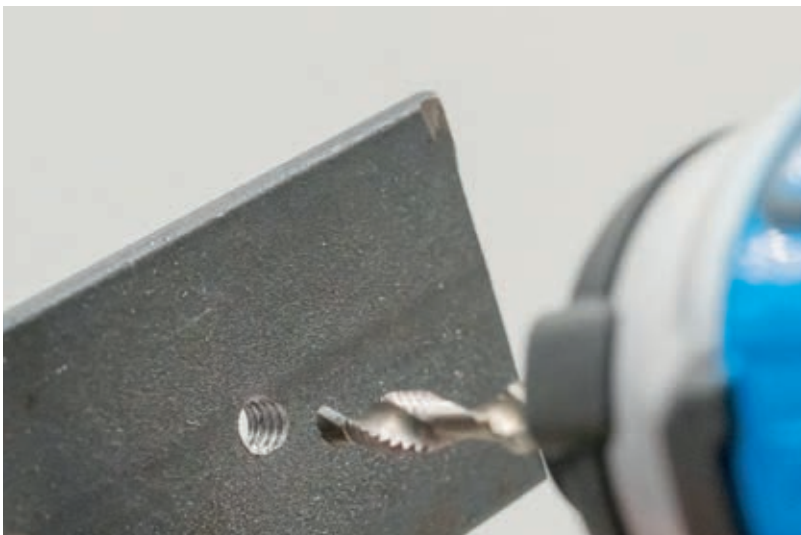

- **3 funciones en 1: Taladrado, Roscado, Avellanado**
- **Roscas limpias y precisas**
- **3 fonctions in 1: Drilling, threading, Countersinking**
- **Clean and accurate threads**
- **3 fonctions en 1 : Perçage, taraudage, fraisage**
- **Filetages propres et précis**



Ref. **1635**

AVELLANADOR 5Z MANGO E6.3

E6.3 Shank 5Z Countersink
Fraise à noyer 5Z queue E6.3

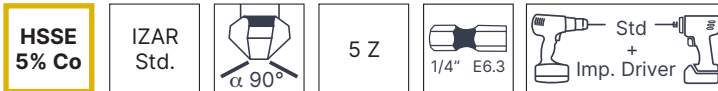
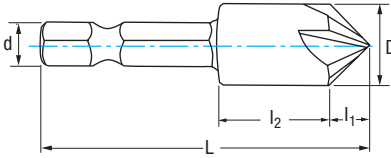

Aceros <850 N/mm ² Steel / Aciers	INOX Stainless Steel Acier INOX	Cobre Copper Cuivre	Aluminio Aluminium	Termoplásticos Thermoplastics Thermoplastiques	Madera Wood Bois
---	--	----------------------------------	------------------------------	---	-------------------------------

- Mecanizado silencioso gracias a los 5 filos de corte
- Poca vibración y acabado excelente
- High number of cutting edges allows a quiet cutting performance
- Chatter-free cutting performance. Excellent surface finishing
- Usinage silencieux grâce aux 5 arêtes de coupe
- Vibration réduite, performance de coupe sans bavardage. Excellente finition de surface

D mm	L mm	l1 mm	l2 mm	d mm	Nº Art.	€
12,00	48,50	6,00	16,50	6,35	59009	
16,00	49,50	8,00	15,50	6,35	59012	
19,00	50,00	9,50	14,50	6,35	59015	

Línea 33 cm - Ref. 1635

18 cm		∅	12	16	19
		Pcs	2	2	2
Ref. 4995 - Nº Art. 84063: €					

Display 76 - Refs. 3610 - 1635 - 1622 - 1614 - 1616



		Ref. 3610					Ref. 1635				
∅		M3	M5	M6	M8	M10	12	16	19		
Pcs		1	1	1	1	1	1	1	1		
		Ref. 1622			Ref. 1614						
∅		4-12	4-20	6-30	M3	M4	M5	M6	M8		
Pcs		1	1	1	2	2	2	2	2		
		Ref. 1616									
∅		2	3	4	4,50	5	6	7	8	9	10
Pcs		5	5	5	5	5	5	3	3	3	3
Ref. 4995 - Nº Art. 85249 €											



Ref. **1839**

BROCA-CORONA DIAMANTE PORCELÁNICO MANGO E6.3

E6.3 Shank Porcelain Diamond Core Bit
Foret-Trépan diamant porcelaine queue E6.3

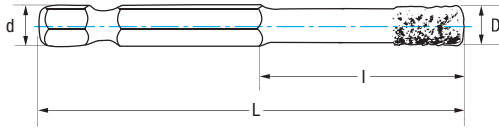

Uso / Use / Usage

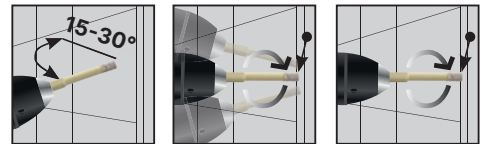

Porcelánico
Porcelain
Porcelaine

Cerámica
Ceramics
Céramique

- Grano de diamante fino adecuado para materiales duros
- Incluye un relleno especial de cera que se va disolviendo en el taladrado, ayudando en la refrigeración
- Fine grit size of the diamond, suitable for hard materials
- The special wax filled core aids cooling and lubrication
- Grain de diamant fin adapté aux matériaux durs
- Inclut un remplissage spécial de cire qui se dissout pendant le perçage, aidant au refroidissement

D mm	L mm	I mm	d mm		Nº Art.	€
5,00	67	10	6,35	1	31564	
6,00	67	10	6,35	1	31565	
8,00	80	10	6,35	1	31566	
10,00	80	10	6,35	1	31567	
12,00	80	10	6,35	1	31568	

Línea 33 cm - Ref. 1839

22 cm		∅	5	6	8	10	12
		Pcs	3	3	3	3	3
Ref. 4995 - Nº Art. 84066:							€

Display 77 - Refs. 1834 - 1601 - 1839 - 1834 - 1613



∅	Ref. 1834			Ref. 1601						
	Pcs	8	10	12	4	5	6	8	10	
	5	2	2	5	5	3	3	3		
∅	Ref. 1839						Ref. 1834			
	Pcs	5	6	6	8	10	12	5	6	
	3	3	3	3	3	3	5	5		
∅	Ref. 1613									
	Pcs	2	3	4	4,50	5	6	7	8	9
	3	3	3	3	3	3	1	1	1	1
Ref. 4995 - Nº Art. 85250: €										

Ref. **1834**

BROCA VIDRIO Y AZULEJO 4Z+

4Z+ Glass and Soft Tiles Drill Bit
Foret verre et carreau 4Z+

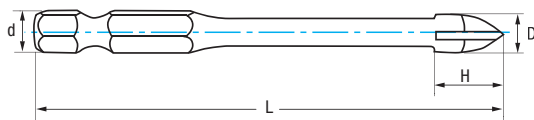

MD/HM TCT					4 Z		
--------------	--	--	--	--	-----	--	--

Vidrio Glass Verre	Cerámica Ceramics Céramique	Porcelánico Blando Soft Porcelain Porcelaine tendre
---------------------------------	--	--

- Punta metal duro con un afilado exclusivo IZAR
- Perforación con precisión debido a la geometría de la punta
- Sus 4 filos de corte permiten una rápida perforación
- Carbide tip with an exclusive IZAR sharpness
- Precision drilling due to the tip's geometry
- Its 4 cutting edges allow for fast drilling
- Pointe en carbure avec un affûtage exclusif IZAR
- Perçage précis grâce à la géométrie de la pointe
- Ses 4 arêtes de coupe permettent un perçage rapide

D mm	d mm	L mm	H mm		Nº Art.	€
5	6,35	75	9,50	1	31873	
6	6,35	75	10,50	1	31992	
8	6,35	85	12,50	1	32075	
10	6,35	85	14,50	1	32099	
12	6,35	90	16,50	1	32117	



6 Sets

Nº Art.	€
69405	



Set 5 Pcs

D mm	Nº Art.	€
5, 6, 8, 10, 12	69403	

Línea 33 cm - Ref. 1834



∅	5	6	8	10	12
Pcs	5	5	5	5	5

Ref. 4995 - Nº Art. 84069: €



Ref. **1654**

BROCA ESPIRAL 3Z TORNILLO EN PUNTA MANGO E6.3

3Z Screw-Point E6.3 Shank Auger Bit
Foret spirale 3Z vis en pointe queue E6.3

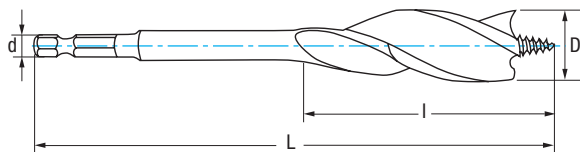

Maderas Duras
Hard Wood
Bois dur

- Gran rendimiento
- Rápido taladrado
- High performance
- Fast drilling
- Haut rendement
- Perçage rapide

D mm	L mm	l mm	d mm		Nº Art.	€
13,00	159	55	6,35	1	58512	
16,00	159	64	6,35	1	58530	
18,00	159	68	6,35	1	58539	
20,00	159	76	6,35	1	58548	
22,00	159	80	6,35	1	58557	
25,00	159	86	6,35	1	58575	
32,00	159	86	6,35	1	58647	

Línea 33 cm - Ref. 1654



∅	16	18	20	22	25
Pcs	5	5	5	5	5

Ref. 4995 - Nº Art. 84072: €



Ref. **1523**

PUNTA ATORNILLAR IMPACTO MANGO E6.3

Impact Screwdriver Bit E6.3 Shank
Embout visage Impact queue E6.3



S2
material

60
HRC

d =
6,35 mm



- Larga vida útil
- Soporta grandes pares de torsión
- Óptimo acople entre la punta y la cabeza del tornillo
- Long life
- Suitable for high-torque
- Optimal fit between the tip and the screw head
- Longue durée de vie
- Supporte de grands couples de torsion
- Adaptation optimale entre la pointe et la tête de la vis

PHILLIPS



Tipo Type	L mm	DIN	Torque (Nm)		Nº Art.	€ pack
PH 1	50	E 6.3	5,00	2	58907	
PH 2	50	E 6.3	14,00	2	22807	
PH 3	50	E 6.3	33,60	2	22816	

POZIDRIVE



PZ 1	50	E 6.3	5,00	2	58910	
PZ 2	50	E 6.3	14,00	2	22818	
PZ 3	50	E 6.3	29,40	2	22820	

TORX



TX 20	50	E 6.3	12,70	2	22836	
TX 25	50	E 6.3	19,00	2	22839	
TX 30	50	E 6.3	37,40	2	22843	
TX 40	50	E 6.3	65,10	2	22845	



Ref. **1520**

PUNTA ATORNILLAR

Screwdriver Bit
Embout vissage



Standard d = 6,35 mm

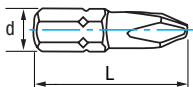

GAMA
Range
Gamme



Tipo Type	D mm	L mm	DIN	Nº Art.	€ pack	Nº Art.	€ pack	Nº Art.	€ pack	Nº Art.	€ pack	Nº Art.	€ pack
-----------	------	------	-----	---------	--------	---------	--------	---------	--------	---------	--------	---------	--------

ALLEN



HEX	2	25	C 6.3	23418		23425		23426		23429			
HEX	2,5	25	C 6.3	23430		23431		23432		23433			
HEX	3	25	C 6.3	83771		33154		23445		23446			
HEX	4	25	C 6.3	83772		33155		23447		23448			
HEX	5	25	C 6.3	83773		33156		23449		23450			
HEX	6	25	C 6.3	23451		23453		23454		23455			
HEX	7	35	C 6.3	23456		23457		23458		23459			
HEX	8	35	C 6.3	23460		23461		23462		23463			

PHILLIPS



PH	0	25	C 6.3	23464		23465		23466		23468			
PH	1	25	C 6.3	83774		33138		23469		23470			
PH	2	25	C 6.3	83776		33139		23473		23475		23476	
PH	3	25	C 6.3	83778		33140		23482		23483			
PH	4	35	C 6.3	23505		23506		23509		23511			
PH	1	50	E 6.3	83775		22647		23471		23472			
PH	2	50	E 6.3	83777		22654		23477		23478		23479	
PH	3	50	E 6.3	83779		22659		23503		23504			

POZIDRIVE



PZ	0	25	C 6.3	23513		23515		23561		23562			
PZ	1	25	C 6.3	83780		33141		23570		23571			
PZ	2	25	C 6.3	83782		33142		23585		23588		23589	
PZ	3	25	C 6.3	83784		33143		23594		23596			
PZ	4	35	C 6.3	23600		23601		23602		23606			
PZ	1	50	E 6.3	83781		23578		23579		23580			
PZ	2	50	E 6.3	83783		22663		23590		23592		23593	
PZ	3	50	E 6.3	83785		22664		23597		23599			

PLANA / Flat / Plate



SL	3,0x0,5	25	C 6.3	23609		23615		23616		23618			
SL	4,0x0,5	25	C 6.3	23619		23620		23622		23624			
SL	4,5x0,6	25	C 6.3	83786		33151		23669		23672			
SL	5,5x0,8	25	C 6.3	83787		33152		23693		23702			
SL	5,5x1,0	25	C 6.3	23735		23738		23741		23750			
SL	6,0x1,0	25	C 6.3	23751		23752		23754		23755			
SL	6,5x1,2	25	C 6.3	83788		33153		23757		23758			
SL	8,0x1,2	30	C 6.3	23770		23772		23773		23774			
SL	4,0x0,5	50	E 6.3	23627		23638		23660		23663			
SL	4,5x0,6	50	E 6.3	23678		22666		23681		23683			
SL	5,5x0,8	50	E 6.3	23705		22668		23714		23723			
SL	6,5x1,2	50	E 6.3	23760		22669		23766		23769			



Ref. **1520**

PUNTA ATORNILLAR

Screwdriver Bit
Embout vissage

GAMA
Range
Gamme



Tipo Type	D mm	L mm	DIN	Nº Art.	€ pack	Nº Art.	€ pack	Nº Art.	€ pack	Nº Art.	€ pack	Nº Art.	€ pack
TX	5	25	C 6.3	23805		23806		23807		23816			
TX	6	25	C 6.3	23817		23818		23819		23820			
TX	7	25	C 6.3	23821		23822		23832		23833			
TX	8	25	C 6.3	23835		66723		23837		23838			
TX	9	25	C 6.3	23848		23851		23853		23854			
TX	10	25	C 6.3	83789		33144		23855		23856			
TX	15	25	C 6.3	83791		33145		23859		23860		23861	
TX	20	25	C 6.3	83793		33146		23866		23869		23872	
TX	25	25	C 6.3	83795		33147		23877		23878		23879	
TX	27	25	C 6.3	23907		33148		23908		23910			
TX	30	25	C 6.3	83797		33149		23915		23919		23920	
TX	40	25	C 6.3	83799		33150		23924		23925			
TX	10	50	E 6.3	83790		22671		23857		23858			
TX	15	50	E 6.3	83792		22674		23863		23864			
TX	20	50	E 6.3	83794		22675		23873		23874		23875	
TX	25	50	E 6.3	83796		22676		23894		23905		23906	
TX	27	50	E 6.3	23911		22677		23912		23913			
TX	30	50	E 6.3	83798		22678		23921		23922		23923	
TX	40	50	E 6.3	83800		22683		23926		23927			

TORX



TORX SEGURIDAD
Security Torx Sécurité



TS	10	25	C 6.3	31098		23949		23950		23951			
TS	15	25	C 6.3	31099		23952		23954		23956			
TS	20	25	C 6.3	31100		23959		23960		23961			
TS	25	25	C 6.3	31101		23962		23963		23964			
TS	27	25	C 6.3	31102		23965		23966		23967			
TS	30	25	C 6.3	31103		23970		23972		23973			
TS	40	25	C 6.3	31104		23974		23975		23998			

SQUARE ROBERTSON



SQ	1	25	C 6.3	23775		23776		23778		23779			
SQ	2	25	C 6.3	23786		23787		23788		23789			
SQ	3	25	C 6.3	23795		23796		23797		23798			
SQ	1	50	E 6.3	23781		23782		23784		23785			
SQ	2	50	E 6.3	23790		23791		23792		23794			
SQ	3	50	E 6.3	23799		23801		23802		23804			

TRIWING



TRW	1	25	C 6.3	23928		23929		23930					
TRW	2	25	C 6.3	23931		23932		23933					
TRW	3	25	C 6.3	23934		23935		23936					
TRW	4	25	C 6.3	23937		23938		23939					
TRW	5	25	C 6.3	23940		23941		23942					
TRW	6	25	C 6.3	23943		23944		23945					
TRW	8	25	C 6.3	23946		23947		23948					

XZN



XZN	4	25	C 6.3	24016		24027		24029					
XZN	5	25	C 6.3	24031		24032		24033					
XZN	6	25	C 6.3	24034		24041		24043					
XZN	8	25	C 6.3	24045		24046		24047					
XZN	10	25	C 6.3	24056		24117		24120					



Display 71 - Ref. 1520



	PZ 1	PZ 1	PH 1	PH 1	TX 10	TX 10	TX 15	TX 15	HEX 3	SL 4,5x0,6	
L	25 mm	50 mm	25 mm	50 mm	25 mm	50 mm	25 mm	50 mm	25 mm	25 mm	
Pcs	5	5	5	5	5	5	5	5	5	5	
	PZ 2	PZ 2	PH 2	PH 2	TX 20	TX 20	TX 25	TX 25	HEX 4	SL 5,5x0,8	
L	25mm	50mm	25mm	50mm	25mm	50mm	25mm	50mm	25mm	25mm	
Pcs	5	5	5	5	5	5	5	5	5	5	
	PZ 3	PZ 3	PH 3	PH 3	TX 30	TX 30	TX 40	TX 40	HEX 5	SL 6,5x1,2	
L	25mm	50mm	25mm	50mm	25mm	50mm	25mm	50mm	25mm	25mm	
Pcs	5	5	5	5	5	5	5	5	5	5	
	SET			SET			SET		Quick-lock INOX	Magnético IND	Magnético IND
Pcs	3			3			3		3	3	3

Ref. 4995 - N° Art. 83801: €

Box-Pallet - Ref. 1520

Set 13 Pcs



Cont.	N° Art.	€
PH: 1 - 2 - 3 +	83769	
PZ: 1 - 2 - 3 +		
T: 10 - 15 - 20 - 25 - 30 - 40		

12 Sets

N° Art.	€
83770	





SET PUNTAS DE PRECISIÓN Precision Screw Bit Set Set embouts vissage de précision



6 Sets

Nº Art.	€
21335	

58
pcs

Set 58 Pcs

Nº Art.	€
21334	



48 Puntas / Bits / Embouts material S2

PH	1.0 - 1.5 - 2.0 - 2.5 - 3.0 - 3.5
HEX	0.9 - 1.3 - 1.5 - 2.0 - 2.5 - 3.0 - 3.5 - 4.0 - 4.5 - 5.0 - 6.0
TS	2 - 3 - 4 - 5 - 6 - 7 - 8 - 9 - 10 - 15 - 20
SL	1.0 - 1.5 - 2.0 - 2.5 - 3.0 - 3.5
P	0.8 - 1.2 - 1.5 - 2.0
Y	0.8 - 2.0 - 2.5 - 3.0
	1.5
	SQ 0 - 1 - 2
	TA 2.0 - 2.3

6 Vasos / Sockets / Douilles hex. material CrV

M2.5 - M3.0 - M3.5 - M4.0 - M4.5 - M5.0

2 Adaptadores / Adaptors / Adaptateurs

H4.0 → H6.3	H6.3 → H4.0
-------------	-------------

1 Destornillador Profesional Aleación de Aluminio Professional Aluminum Alloy Screwdriver Tournevis en alliage aluminium
1 Alargador Flexible Flexible Extension Bar Rallonge Souple

PUNTAS DE GRADO INDUSTRIAL

- Acero S2 de gran dureza (60 HRC)
- Cuellos largos para un mejor acceso
- Magnéticos

INDUSTRIAL GRADE SCREW BITS

- Shock-resisting S2 Steel (60 HRC)
- Long neck. Suitable for hard-to-reach areas
- Magnetic

EMBOUTS À DEGRÉ INDUSTRIEL

- Acier S2 de grande dureté (60 HRC)
- Couds longs pour un meilleur accès
- Magnétiques



Ref. **1524**

PUNTA ATORNILLAR EXTRA LARGA

Extra Long Screwdriver Bit
Embout vissage extra-long



Standard

d =
6,35 mm

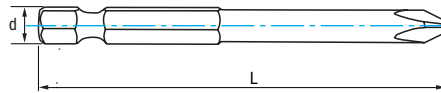

1
Uds



5
Uds

Tipo Type	D mm	L mm	DIN	Nº Art.	€ pack	Nº Art.	€ pack
--------------	---------	---------	-----	------------	-----------	------------	-----------

PHILLIPS



PH	1	75	E 6.3	23222		23225	
PH	2	75	E 6.3	23270		23271	
PH	3	75	E 6.3	23278		23279	
PH	1	100	E 6.3	23227		23229	
PH	2	100	E 6.3	23274		23275	
PH	3	100	E 6.3	23280		23281	
PH	1	150	E 6.3	23230		23231	
PH	2	150	E 6.3	23276		23277	
PH	3	150	E 6.3	23282		23283	

POZIDRIVE



PZ	1	75	E 6.3	23284		23285	
PZ	2	75	E 6.3	23290		23291	
PZ	3	75	E 6.3	23296		23297	
PZ	1	100	E 6.3	23286		23287	
PZ	2	100	E 6.3	23292		23293	
PZ	3	100	E 6.3	23298		23299	
PZ	1	150	E 6.3	23288		23289	
PZ	2	150	E 6.3	23294		23295	
PZ	3	150	E 6.3	23300		23301	

TORX



Tx	10	75	E 6.3	23330		23333	
Tx	15	75	E 6.3	23342		23351	
Tx	20	75	E 6.3	23359		23360	
Tx	25	75	E 6.3	23366		23367	
Tx	27	75	E 6.3	23384		23387	
Tx	30	75	E 6.3	23395		23398	
Tx	40	75	E 6.3	23408		23409	
Tx	10	100	E 6.3	23334		23338	
Tx	15	100	E 6.3	23352		23353	
Tx	20	100	E 6.3	23361		23362	
Tx	25	100	E 6.3	23374		23376	
Tx	27	100	E 6.3	23388		23390	
Tx	30	100	E 6.3	23399		23400	
Tx	40	100	E 6.3	23410		23411	
Tx	10	150	E 6.3	23339		23340	
Tx	15	150	E 6.3	23355		23357	
Tx	20	150	E 6.3	23364		23365	
Tx	25	150	E 6.3	23382		23383	
Tx	27	150	E 6.3	23392		23393	
Tx	30	150	E 6.3	23404		23405	
Tx	40	150	E 6.3	23414		23417	





Zirkonio



NUEVA PUNTA
Máximo rendimiento

NEW TIP
Maximum performance

NOUVELLE POINTE
Rendement maximal



Ref. **1015**

BROCA MANGO CILÍNDRICO ZIRKONIO

Zirkonio Straight Shank Drill Bit
Foret queue cylindrique Zirkonio



▶ Video



ZIRKONIO

Ángulo punta 118°

- Autocentradora
- Ideal taladro portátil
- Geometría especial diseñada para reducir el esfuerzo de corte

Nuevo recubrimiento Zirkonio de última generación por PVD

- Basado en ZRN
- Bajo coeficiente de fricción
- Muy resistente a la corrosión
- Adecuado para materiales no férricos
- Evita la adherencia de material en el filo de corte

118° Point Angle

- Autocentering
- Ideal Portable Drilling Machine
- Special Geometry designed for reducing cutting effort

Latest generation Zirkonio coating by PVD

- Based on ZRN
- Low Friction Coefficient
- High Corrosion Resistant
- Appropriate for Non-Ferrous Materials
- Built-Up Edge avoided

Angle Pointe 118°

- Autocentreur
- Perceuse à main
- Géométrie pour réduire l'effort de coupe

Nouveau revêtement Zirkonio dernière génération par PVD

- Base ZRN
- Faible coefficient friction
- Résistant à l'usure
- Recommandé pour aciers non ferreux
- Évite l'adhérence sur les filets de coupe

Ref. **1052**



Extra-Corta / Stub / Extra-courte





Ref. **1050**

BROCA MANGO CILÍNDRICO HSS EXTRA CORTA

HSS Straight Shank Stub Drill Bit
Foret queue cylindrique HSS extra-courte



D mm	L mm	I mm		Nº Art.	€
1,10	28	7	10	48338	
1,20	30	8	10	48341	
1,30	30	8	10	48344	
1,40	32	9	10	48347	
1,70	34	10	10	48350	
6,90	74	34	10	48353	
7,10	74	34	10	48362	
7,30	74	34	10	48365	
7,60	79	37	10	48368	
7,70	79	37	10	48383	
7,90	79	37	10	48386	
8,10	79	37	10	48389	
8,20	79	37	10	48392	
8,30	79	37	10	48395	
8,40	79	37	10	48398	
8,70	84	40	10	20720	
8,80	84	40	10	48401	
8,90	84	40	10	48404	

D mm	L mm	I mm		Nº Art.	€
9,20	84	40	10	48407	
9,30	84	40	10	48410	
9,40	84	40	10	48413	
9,60	89	43	10	48416	
9,70	89	43	10	48419	
9,80	89	43	10	48422	
9,90	89	43	10	48335	
10,10	89	43	1	48428	
10,15	89	43	1	16195	
10,30	89	43	1	48431	
10,80	95	47	1	48434	
11,20	95	47	1	48437	
11,80	95	47	1	48449	
12,10	102	51	1	48452	
12,20	102	51	1	48455	
15,25	115	58	1	48797	
15,75	115	58	1	20834	



Ref. **1065**

BROCA MANGO CILÍNDRICO ZIRKONIO

Zirkonio Straight Shank Drill Bit
Foret queue cylindrique Zirkonio



D mm	L mm	I mm		Nº Art.	€
6,80	109	69	1	25971	
12,50	151	101	1	40206	



Ref. **1800**

PORTABROCAS MANUAL

Hand Drill-Chucks
Mandrin à main



CAP.	Nº Art.	€
0,3 - 3,5	45431	



- Portabrocas fabricado en aleación de aluminio
- Aluminium alloyed body
- Mandrin fabriqué en alliage d'aluminium

Sets - Ref. 1015

Set 1405



50 Pcs

Cont. Ø	Nº Art.	€
1 - 5,9 × 0,1 mm	59126	

Set 1408



41 Pcs

Cont. Ø	Nº Art.	€
6 - 10 × 0,1 mm	59129	

Set Ref. 3100 + 1015 Zirkonio

14 Pcs



Cont. Ø	Nº Art.	€
Machos / Taps / Tarauds DIN 371: M3-M4-M5-M6-M8-M10 + DIN 376: M12 Brocas / Drill Bits / Forets Zirkonio: 2,5-3,3-4,2-5,0-6,8-8,5-10,2	56424	

Set Ref. 3150 + 1015 Zirkonio

14 Pcs



Cont. Ø	Nº Art.	€
Machos / Taps / Tarauds DIN 371: M3-M4-M5-M6-M8-M10 + DIN 376: M12 Brocas / Drill Bits / Forets Zirkonio: 2,5-3,3-4,2-5,0-6,8-8,5-10,2	56428	

Ref. 3119

MACHO RECTO MÁQUINA MÉTRICA NORMA ISO 529

ISO 529 Norm Standard Metric Machine Straight Tap

Taraud droit machine métrique norme ISO 529



M	P	L mm	l mm	d mm	a mm	Z	Nº Art.	€
M2	0,40	41	8	2,50	2,00	2	77478	
M2,5	0,45	44	9,5	2,80	2,24	2	77479	
M3,5	0,60	53	13	4,00	3,15	3	69562	
M4,5	0,75	58	16	5,00	4,00	3	69570	
M7	1,00	66	19	6,30	5,00	3	69583	



Ref. **3109**

MACHO RECTO MÁQUINA MÉTRICA NORMA ISO 529

ISO 529 Norm Standard Metric Machine Straight Tap

Taraut droit machine métrique norme ISO 529

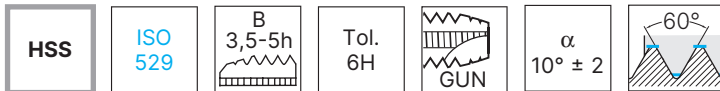
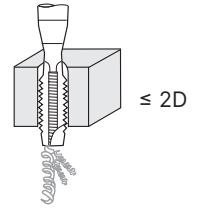
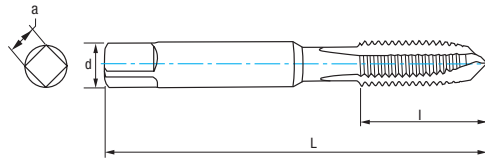

Aceros
<math><850 \text{ N/mm}^2</math>
Steel / Aciers

Cobre
Copper
Cuivre

Aluminio
Aluminium



New!

M	P	L mm	l mm	d mm	a mm	Z	Nº Art.	€	Nº Art. TIN	€
M3	0,50	48	11	3,15	2,50	3	38180		31717	
M3,5	0,60	53	13	4,00	3,15	3	38181		70208	
M4	0,70	53	13	4,00	3,15	3	38182		31718	
M4,5	0,75	58	16	5,00	4,00	3	38183		70229	
M5	0,80	58	16	5,00	4,00	3	38373		31719	
M6	1,00	66	19	6,30	5,00	3	38185		31720	
M7	1,00	66	19	6,30	5,00	3	38186		70235	
M8	1,25	72	22	8,00	6,30	3	38187		31721	
M10	1,50	80	24	10,00	8,00	3	38188		31722	
M12	1,75	89	29	9,00	7,10	3	38189		31729	
M14	2,00	95	30	11,20	9,00	3	38190		31730	
M16	2,00	102	32	12,50	10,00	3	38191		31732	
M18	2,50	112	37	14,00	11,20	3	38192		31734	
M20	2,50	112	37	14,00	11,20	3	38193		31736	
M22	2,50	118	38	16,00	12,50	3	38194		31737	
M24	3,00	130	45	18,00	14,00	3	38195		31746	
M27	3,00	135	45	20,00	16,00	3	38196		31747	
M30	3,50	138	48	20,00	16,00	3	38197		31748	
New! M33	3,50	151	51	22,40	18,00	4	31585		31749	
New! M36	4,00	162	57	25,00	20,00	4	31588		31751	
New! M39	4,00	170	60	28,00	22,40	4	31605		31752	
New! M42	4,50	170	60	28,00	22,40	4	31607		31753	
New! M45	4,50	187	67	31,50	25,00	4	31609		31754	
New! M48	5,00	187	67	31,50	25,00	4	31616		31755	



Ref. **3157**

MACHO HELICOIDAL MÁQUINA MÉTRICA NORMA ISO 529

ISO 529 Norm Standard Metric Machine Spiral Tap

Tarautado helicoidal machine métrique norme ISO 529

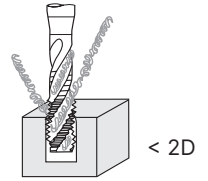
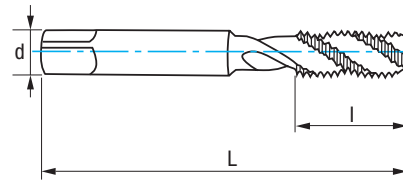

HSS

ISO 529



Tol. 6H

α 12-14°



Aceros
<850 N/mm²
Steel / Aciers

Cobre
Copper
Cuivre

Aluminio
Aluminium



New!

M	P	L mm	l mm	d mm	a mm	Z	Nº Art.	€	Nº Art. TIN	€
M3	0,50	48	11	3,15	2,50	3	38198		31723	
M3,5	0,60	53	13	4,00	3,15	3	38199		70194	
M4	0,70	53	13	4,00	3,15	3	38201		31724	
M5	0,80	58	16	5,00	4,00	3	38206		31725	
M6	1,00	66	19	6,30	5,00	3	38209		12168	
M7	1,00	66	19	6,30	5,00	3	38211		70197	
M8	1,25	72	22	8,00	6,30	3	38214		31726	
M10	1,50	80	24	10,00	8,00	3	38216		31728	
M12	1,75	89	29	9,00	7,10	3	38226		31756	
M14	2,00	95	30	11,20	9,00	3	38228		31757	
M16	2,00	102	32	12,50	10,00	3	38229		31758	
New! M18	2,50	112	37	14,00	11,20	4	31627		31759	
New! M20	2,50	118	38	16,00	12,50	4	31629		31760	
New! M22	2,50	130	45	18,00	14,00	4	31630		31761	
New! M24	3,00	135	45	20,00	16,00	4	31634		31762	
New! M27	3,00	138	48	20,00	16,00	4	31635		31763	
New! M30	3,50	151	51	22,40	18,00	4	31638		31764	
New! M33	3,50	162	57	25,00	20,00	4	31586		31766	
New! M36	4,00	170	60	28,00	22,40	4	31604		31767	
New! M39	4,00	170	60	28,00	22,40	4	31606		31768	
New! M42	4,50	187	67	31,50	25,00	4	31608		31769	
New! M45	4,50	187	67	31,50	25,00	4	31612		31772	
New! M48	5,00	187	67	31,50	25,00	4	31620		31775	



Ref. **3415**

ACEITES DE CORTE Y REFRIGERANTES

Cutting Oils & Water Soluble Fluids
Huiles de coupe et lubrifiants



MULTI

Multiusos

Multiusos - Multi-purpose - Multifonction

APLICACIÓN:

Mecanizado de aceros duros, inoxidables, aleaciones de cobre y toda clase de metales

Fuertemente aditivado para lubricar y proteger contra la corrosión

APPLICATION:

Machining of hard steels, stainless steels, copper alloys and all kinds of metals

Highly additivated for lubrication and corrosion protection

APPLICATION:

Usinage d'aciers durs, inoxydables, alliages de cuivre et tous types de métaux

Fortement additivé pour la lubrification et la protection contre la corrosion



Cont. 400ml

Nº Art. 84040

€



Pulveriza abiertamente con la cánula hacia abajo

Spray openly with the nozzle facing down

Vaporise ouvertement avec la canule vers le bas



Pulveriza con precisión con la cánula hacia arriba

Spray precisely with the nozzle facing up

Vaporise précisément avec la canule vers le haut



12 UNI

Nº Art.

€

Box Price!

84335

Ref. **1529**

ADAPTADORES PUNTAS ATORNILLAR

Screwdriver Bit Adaptors
Adaptateurs embouts vissage



Adaptador de 1/4 a 1/2

1/4 to 1/2 Adaptor

Adaptateur de 1/4 à 1/2

Para uso de herramientas de mango E6.3(1/4) en llaves de impacto 1/2

It allows the use of E6.3(1/4) shank tools on a 1/2 Impact wrench

Pour utiliser des outils à queue hexagonale E6.3(1/4) avec clés à choc de 1/2



mm	L mm	d mm		Nº Art.	€ pack
12,7	50	6,35	1	75107	





IZAR CUTTING TOOLS, S.A.L.

C.I.F.: A-48932826

Parque Empresarial Boroa 2B2

48340 AMOREBIETA (Bizkaia)

Spain

izartool.com

COMERCIAL NACIONAL ✉ comercial@izartool.com

**PEDIDOS Y
ATENCIÓN A CLIENTES** ☎ 94 630 02 41

SERVICIO TÉCNICO ☎ 94 630 02 43

EXPORT SALES ✉ export@izartool.com

**ORDERS & CUSTOMER
ASSISTANCE** ☎ +34 94 630 02 46

VENTES FRANCE ✉ france@izartool.com
☎ +34 94 630 02 45

VENDITA ITALIA ✉ italia@izartool.com
☎ +34 94 630 02 45



izartool.com



Todas nuestras publicaciones se imprimen en papel ecológico procedente de fuentes responsables con el medioambiente y la sociedad.

All our publications are printed on ecological paper from environmentally and socially responsible sources.

Toutes nos publications sont imprimées sur du papier écologique issu de sources écologiquement et socialement responsables.